

Project:

Model: VSHP—Vertical Stack Heat Pump

Standard Efficiency (SE) Series

Dev. G

Date:

Revision: 0

OMEGA Job #:

SUBMITTAL SET

Presented By:





SUMMARY PAGE

- Vertical Stack Heat Pump w/ Standard Efficiency Chassis (SE)
- Unit Mounted Non-Fused Disconnect Switch
- ECM Fan with Forward Curved DWDI Blower
- Advanced Microprocessor Control Board

VSHP (SE) - PERFORMANCE TABLE—ISO WATER LOOP CONDITIONS

| Unit Model | Refrig. | Air Flow (SCFM) | Water Flow (GPM) | WPD (FT) | WLHP Cooling ¹ | | WLHP Heating ¹ | | GLHP Cooling ² | | GLHP Heating ² | |
|------------|---------|-----------------|------------------|----------|---------------------------|------|---------------------------|-----|---------------------------|------|---------------------------|-----|
| | | | | | Capacity (BTUH) | EER | Capacity (BTUH) | COP | Capacity (BTUH) | EER | Capacity (BTUH) | COP |
| VSHP 020 | R-410A | 200 | 1.5 | 3.3 | 5,800 | 12.2 | 7,200 | 4.3 | 6,700 | 14.1 | 5,300 | 3.2 |
| VSHP 030 | R-410A | 350 | 2.6 | 11.0 | 8,900 | 12.5 | 11,900 | 4.5 | 9,200 | 14.1 | 7,500 | 3.2 |
| VSHP 040 | R-410A | 460 | 3.5 | 11.1 | 11,600 | 13.5 | 14,700 | 4.5 | 12,000 | 15.3 | 9,200 | 3.2 |
| VSHP 050 | R-410A | 530 | 4.0 | 14.3 | 15,000 | 15.0 | 17,200 | 4.8 | 15,600 | 16.5 | 10,800 | 3.3 |
| VSHP 060 | R-410A | 630 | 5.1 | 20.2 | 17,900 | 14.5 | 22,500 | 4.5 | 18,600 | 15.7 | 14,000 | 3.2 |
| VSHP 080 | R-410A | 820 | 6.7 | 10.2 | 23,000 | 14.5 | 28,000 | 4.5 | 23,900 | 15.7 | 17,500 | 3.2 |
| VSHP 100 | R-410A | 1010 | 7.9 | 14.2 | 28,700 | 14.5 | 35,500 | 4.6 | 29,900 | 15.6 | 22,200 | 3.2 |
| VSHP 120 | R-410A | 1200 | 9.0 | 18.4 | 36,000 | 13.8 | 43,000 | 4.5 | 36,200 | 15.0 | 28,700 | 3.2 |

¹Performance based on ARI/ISO 13256-1 Water Loop conditions at 86F EWT Cooling, 68F EWT Heating.

²Performance based on ARI/ISO 13256-1 Ground Loop conditions at 77F EWT Cooling, 32F EWT Heating. Cooling performance shown is for 80.6F DB and 66.2F WB entering air.

VSHP (SE) - ELECTRICAL DATA (ECM)

| Model | Supply Voltage | Compressor | | | Blower | | Total Unit FLA | MCA | MaxFuse/Circuit Breaker |
|----------|----------------|------------|--------|------|--------|-----|----------------|------|-------------------------|
| | | Qty | RLA | LRA | HP | FLA | | | |
| VSHP 020 | 208-230/1/60 | 1 | @ 3.0 | 15.0 | 1/4 | 1.0 | 4.0 | 4.8 | 15 |
| VSHP 030 | 208-230/1/60 | 1 | @ 3.7 | 22.0 | 1/4 | 1.1 | 4.8 | 5.7 | 15 |
| VSHP 040 | 208-230/1/60 | 1 | @ 4.7 | 25.0 | 1/4 | 1.2 | 5.9 | 7.1 | 15 |
| VSHP 050 | 208-230/1/60 | 1 | @ 5.6 | 29.0 | 1/3 | 2.1 | 7.7 | 9.1 | 15 |
| VSHP 060 | 208-230/1/60 | 1 | @ 7.4 | 33.0 | 1/3 | 2.6 | 10.0 | 11.9 | 15 |
| VSHP 080 | 208-230/1/60 | 1 | @ 10.9 | 62.9 | 1/2 | 4.2 | 15.1 | 17.8 | 25 |
| VSHP 100 | 208-230/1/60 | 1 | @ 13.5 | 72.5 | 1/2 | 4.2 | 17.7 | 21.1 | 30 |
| VSHP 120 | 208-230/1/60 | 1 | @ 15.4 | 83.9 | 1/2 | 4.2 | 19.6 | 23.5 | 35 |

VSHP (SE)- PHYSICAL DATA

| Model | Cabinet Size | Cabinet (lbs) | Chassis (lbs) | Total Chassis Fluid Volume* | |
|----------|--------------|---------------|---------------|---------------------------------|---------------------------|
| | | | | Fluid Volume (In ³) | Fluid Volume (US gallons) |
| VSHP 020 | X | 153 | 90 | 30.4 | 0.13 |
| VSHP 030 | | | 95 | 30.4 | 0.13 |
| VSHP 040 | | | 95 | 33.8 | 0.15 |
| VSHP 050 | Y | 158 | 98 | 49.8 | 0.22 |
| VSHP 060 | | | 98 | | |
| VSHP 080 | Z | 223 | 110 | 134.0 | 0.58 |
| VSHP 100 | | | 130 | | |
| VSHP 120 | | | 140 | | |

VSHP - ECM FAN DATA

| Model | EC Motor Speed | External Static Pressure Option | Min. SCFM | Rated SCFM | External Static Pressure (in w.g.) | | | | | | | | | | | | |
|---------------|----------------|---------------------------------|-----------|------------|------------------------------------|------|------|------|------|------|------|------|------|------|------|------|------|
| | | | | | 0 | 0.05 | 0.1 | 0.15 | 0.2 | 0.25 | 0.3 | 0.35 | 0.4 | 0.45 | 0.5 | 0.55 | 0.6 |
| | | | | | SCFM | SCFM | SCFM | SCFM | SCFM | SCFM | SCFM | SCFM | SCFM | SCFM | SCFM | SCFM | SCFM |
| 020 | WHISPER* MODE | N/A | N/A | N/A | 210 | 195 | 180 | 160 | 145 | 130 | 115 | 100 | 75 | 55 | - | - | - |
| | LOW | LOW ESP | 150 | 200 | 250 | 240 | 225 | 210 | 200 | 185 | 150 | - | - | - | - | - | - |
| | MED | | | | - | - | 255 | 240 | 225 | 215 | 200 | 190 | 175 | 165 | 150 | - | - |
| | MED | HIGH ESP | | | - | - | 255 | 240 | 225 | 215 | 200 | 190 | 175 | 165 | 150 | - | - |
| | HIGH | | | | - | - | - | - | 260 | 240 | 230 | 220 | 210 | 195 | 185 | 175 | 165 |
| WHISPER* MODE | N/A | | | | N/A | N/A | 225 | 210 | 195 | 175 | 160 | 145 | 130 | 115 | 100 | 85 | 70 |
| 030 | LOW | LOW ESP | 220 | 350 | 315 | 305 | 295 | 285 | 275 | 265 | 250 | 240 | 225 | - | - | - | - |
| | MED | | | | 350 | 340 | 335 | 325 | 315 | 305 | 295 | 285 | 275 | 265 | 255 | 245 | 235 |
| | MED | HIGH ESP | | | 350 | 340 | 335 | 325 | 315 | 305 | 295 | 285 | 275 | 265 | 255 | 245 | 235 |
| | HIGH | | | | - | - | 365 | 355 | 350 | 340 | 330 | 320 | 310 | 305 | 295 | 285 | 275 |
| | WHISPER* MODE | | | | N/A | N/A | N/A | 250 | 230 | 225 | 205 | 180 | 160 | 145 | 125 | 110 | 90 |
| 040 | LOW | LOW ESP | 300 | 460 | 410 | 400 | 390 | 380 | 370 | 365 | 350 | 340 | 330 | 325 | 310 | 300 | - |
| | MED | | | | 460 | 450 | 445 | 440 | 430 | 425 | 415 | 405 | 395 | 385 | 375 | 365 | 355 |
| | MED | HIGH ESP | | | 460 | 450 | 445 | 440 | 430 | 425 | 415 | 405 | 395 | 385 | 375 | 365 | 355 |
| | HIGH | | | | - | - | - | - | 470 | 465 | 455 | 445 | 435 | 430 | 420 | 410 | 400 |
| | WHISPER* MODE | | | | N/A | N/A | N/A | 450 | 430 | 410 | 390 | 370 | 350 | 320 | 300 | 270 | 250 |
| 050 | LOW | LOW ESP | 375 | 530 | 520 | 510 | 490 | 470 | 450 | 430 | 410 | 390 | 375 | - | - | - | - |
| | MED | | | | - | - | 550 | 540 | 520 | 505 | 485 | 470 | 450 | 430 | 410 | 390 | 375 |
| | MED | HIGH ESP | | | - | - | 550 | 540 | 520 | 505 | 485 | 470 | 450 | 430 | 410 | 390 | 375 |
| | HIGH | | | | - | - | - | - | - | - | 555 | 540 | 525 | 510 | 490 | 475 | 460 |
| | WHISPER* MODE | | | | N/A | N/A | N/A | 450 | 430 | 410 | 390 | 370 | 350 | 320 | 300 | 270 | 250 |
| 060 | LOW | LOW ESP | 450 | 630 | 580 | 565 | 550 | 540 | 520 | 505 | 485 | 470 | 450 | - | - | - | - |
| | MED | | | | 640 | 620 | 610 | 595 | 580 | 565 | 555 | 540 | 525 | 510 | 490 | 475 | 460 |
| | MED | HIGH ESP | | | 640 | 620 | 610 | 595 | 580 | 565 | 555 | 540 | 525 | 510 | 490 | 475 | 460 |
| | HIGH | | | | - | - | 675 | 670 | 655 | 650 | 640 | 620 | 610 | 595 | 580 | 565 | 550 |
| | WHISPER* MODE | | | | N/A | N/A | N/A | 620 | 580 | 560 | 520 | 480 | 440 | 410 | 380 | 340 | 300 |
| 080 | LOW | LOW ESP | 600 | 820 | 800 | 760 | 740 | 720 | 695 | 660 | 640 | 620 | - | - | - | - | |
| | MED | | | | 880 | 860 | 840 | 820 | 800 | 780 | 750 | 720 | 700 | 670 | 650 | 625 | 600 |
| | MED | HIGH ESP | | | 880 | 860 | 840 | 820 | 800 | 780 | 750 | 720 | 700 | 670 | 650 | 625 | 600 |
| | HIGH | | | | - | - | - | - | 895 | 880 | 860 | 820 | 805 | 795 | 780 | 770 | 760 |
| | WHISPER* MODE | | | | N/A | N/A | N/A | 620 | 580 | 560 | 520 | 480 | 440 | 410 | 380 | 340 | 300 |
| 100 | LOW | LOW ESP | 750 | 1010 | 960 | 940 | 920 | 890 | 860 | 840 | 820 | 800 | 775 | 750 | - | - | - |
| | MED | | | | 1080 | 1060 | 1040 | 1010 | 990 | 970 | 950 | 930 | 900 | 880 | 860 | 840 | 820 |
| | MED | HIGH ESP | | | 1080 | 1060 | 1040 | 1010 | 990 | 970 | 950 | 930 | 900 | 880 | 860 | 840 | 820 |
| | HIGH | | | | - | - | - | - | 1110 | 1090 | 1070 | 1060 | 1040 | 1020 | 990 | 980 | 960 |
| | WHISPER* MODE | | | | N/A | N/A | N/A | 620 | 580 | 560 | 520 | 480 | 440 | 410 | 380 | 340 | 300 |
| 120 | LOW | LOW ESP | 900 | 1200 | 1120 | 1100 | 1090 | 1070 | 1050 | 1025 | 1010 | 990 | 970 | 940 | 920 | - | - |
| | MED | | | | 1230 | 1200 | 1185 | 1170 | 1150 | 1130 | 1110 | 1095 | 1080 | 1055 | 1040 | 1020 | 1000 |
| | MED | HIGH ESP | | | 1230 | 1200 | 1185 | 1170 | 1150 | 1130 | 1110 | 1095 | 1080 | 1055 | 1040 | 1020 | 1000 |
| | HIGH | | | | 1320 | 1290 | 1275 | 1260 | 1240 | 1225 | 1205 | 1190 | 1175 | 1160 | 1140 | 1120 | 1100 |
| | WHISPER* MODE | | | | N/A | N/A | N/A | 620 | 580 | 560 | 520 | 480 | 440 | 410 | 380 | 340 | 300 |

Note: All airflow ratings are taken at lowest voltage rating of dual rating (ie. 208 volt).
 Airflow ratings include resistance of dry coil, Return Air panel and clean MERV10 air filters.
 *Optional "Whisper" mode is Fan On, Compressor Off mode for constant fresh air circulation.

VSHP SE - CABINET DIMENSIONS –STANDARD SILVER SERIES CABINET

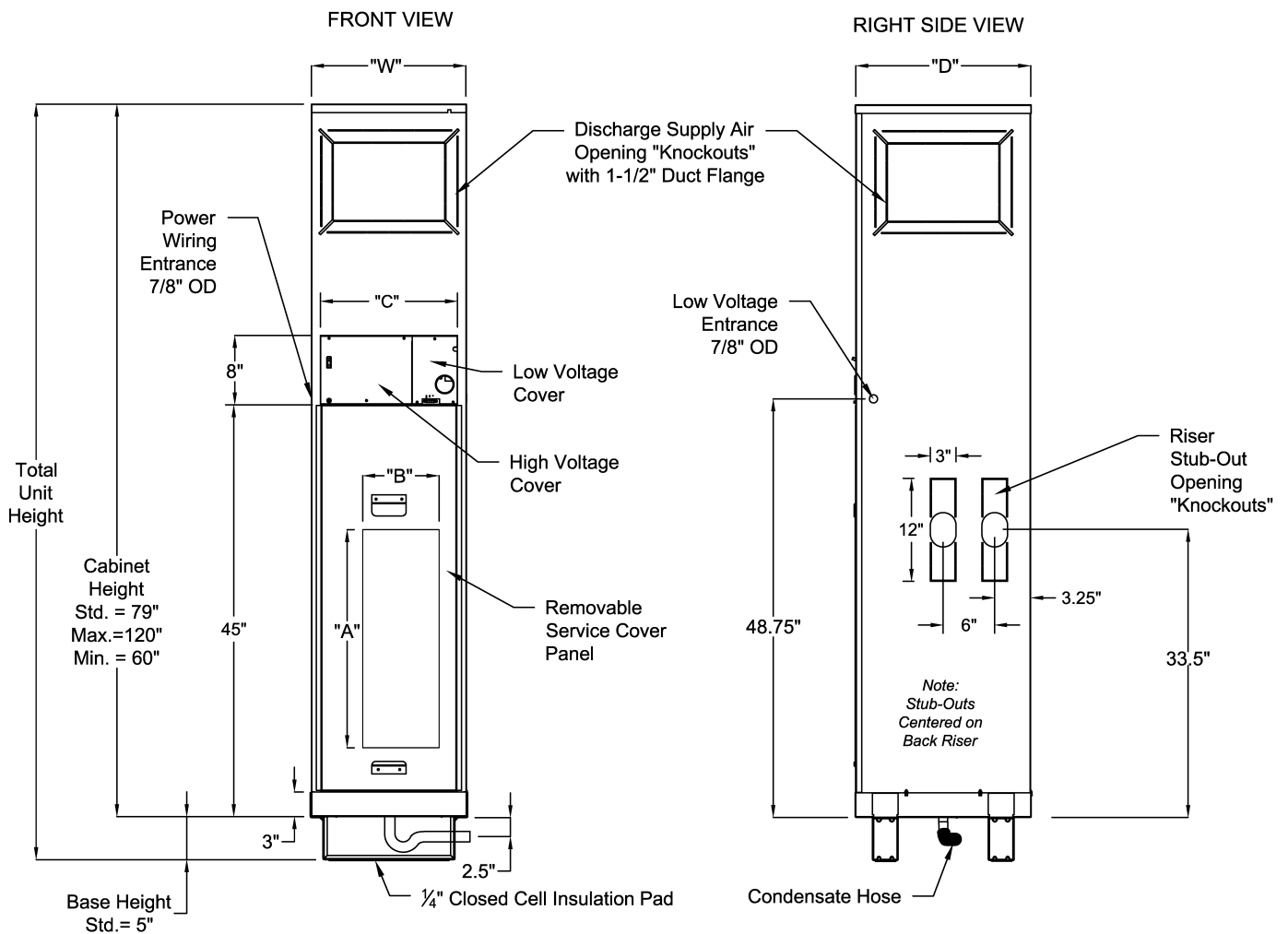

VSHP - CABINET DIMENSIONS & SUPPLY DISCHARGE OPENING SIZES

| Model | Cabinet Size | Dimensions (in) | | | VSHP Supply Discharge Opening (W X H) inches | |
|-----------|--------------|-----------------|------|-----|--|---------|
| | | "W" | "D" | "C" | Horizontal | Top |
| VSHP 020G | X | 16 | 17.5 | 14 | 14 x 8 | 12 x 12 |
| VSHP 030G | | | | | 14 x 8 | 12 x 12 |
| VSHP 040G | | | | | 14 x 10 | 12 x 12 |
| VSHP 050G | Y | 18 | 20.5 | 16 | 16 x 12 | 14 x 12 |
| VSHP 060G | | | | | 16 x 12 | 14 x 12 |
| VSHP 080G | Z | 22 | 24.5 | 20 | 18 x 14 | 14 x 14 |
| VSHP 100G | | | | | 18 x 16 | 16 x 14 |
| VSHP 120G | | | | | 18 x 16 | 16 x 16 |

Note: Discharge opening sizes are customer configurable. Published sizes shown are maximum factory default sizes. Customer to verify discharge opening sizes match design requirements for proper airflow and select appropriate discharge openings at time of order.

Lower riser knockout can be used to match previous generation fan cabinet riser stub-out locations.

VSHP - CABINET DIMENSIONS –OPTIONAL GOLD SERIES CABINET

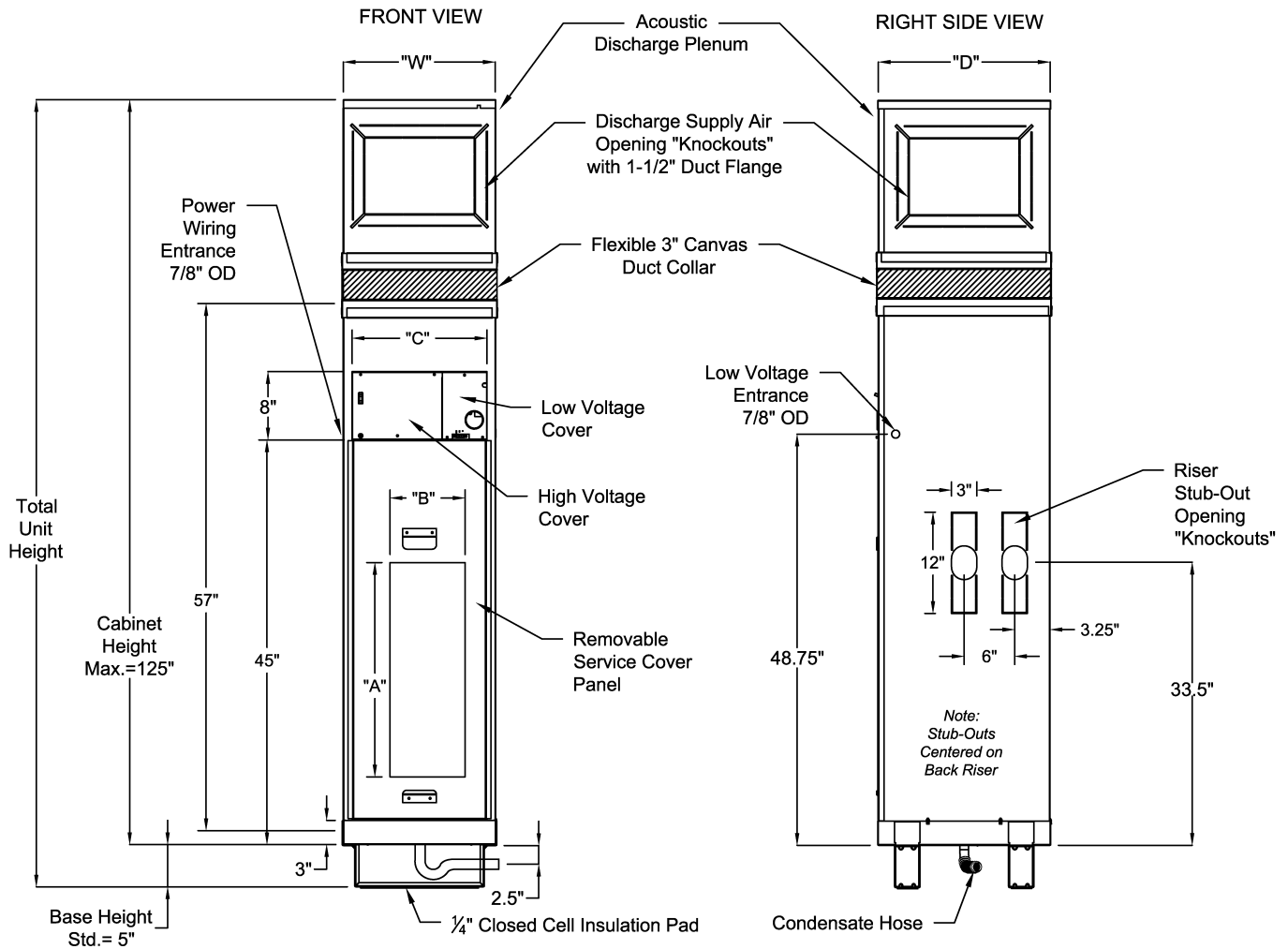

VSHP - CABINET DIMENSIONS & MINIMUM CABINET HEIGHTS (SILVER & GOLD SERIES)

| Model | Cabinet Size | Dimensions (in) | | | Minimum Cabinet Height (in) | |
|-----------|--------------|-----------------|------|-----|-----------------------------|-------------|
| | | "W" | "D" | "C" | Silver Series* | Gold Series |
| VSHP 020G | X | 16 | 17.5 | 14 | 60 / 72 | 80 |
| VSHP 030G | | | | | | |
| VSHP 040G | | | | | | |
| VSHP 050G | Y | 18 | 20.5 | 16 | 60 / 74 | 82 |
| VSHP 060G | | | | | | |
| VSHP 080G | Z | 22 | 24.5 | 20 | 60 / 74 | 86 |
| VSHP 100G | | | | | | |
| VSHP 120G | | | | | | |

* 60in without horizontal (side) discharges

VSHP - STANDARD DISCHARGE OPENING KNOCKOUTS

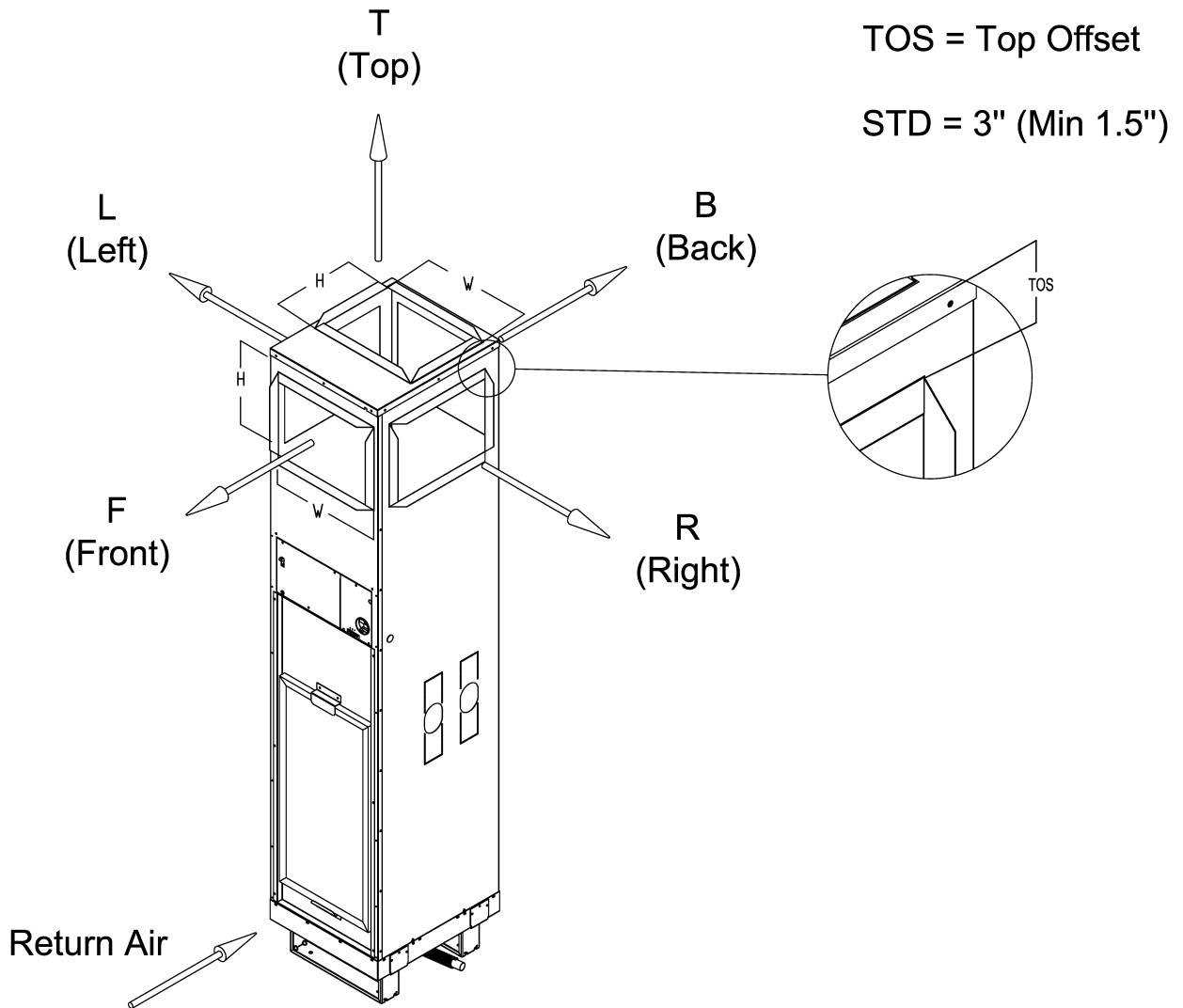

Supply Air Opening Sizes

| Model | VSHP Supply Discharge Opening (W X H) inches | | | | | | | |
|-------------------|--|---------|---------|---------|---------|---------|---------|---------|
| | 020 | 030 | 040 | 050 | 060 | 080 | 100 | 120 |
| Horizontal | 14 x 8 | 14 x 8 | 14 x 10 | 16 x 12 | 16 x 12 | 18 x 14 | 18 x 16 | 18 x 16 |
| Top | 12 x 12 | 12 x 12 | 12 x 12 | 14 x 12 | 14 x 12 | 14 x 14 | 16 x 14 | 16 x 16 |

Notes:

- Discharge opening sizes are customer configurable. Published sizes shown are maximum factory default sizes. Customer to verify discharge opening sizes match design requirements for proper airflow and select appropriate discharge openings at time of order.
- Unit comes standard with field "knockout" style discharge openings on all sides. Discharge flanges are 1-1/2 inches.
- Line of Site Baffles (LOSB) are available where two or more horizontal discharge (Front, Left, Right and/or Back) openings are specified.
- All handing's determined by facing return air opening
- Top Discharge is centered left and right, and offset 2 inches from the back.

VSHP - OPTIONAL LINE OF SIGHT BAFFLE

Optional Line of Sight Baffles (LOSBS) are supplied inside discharge plenum. The LOSB provides occupant privacy between adjacent rooms. Two configurations (LSB-LR or LSB-RL) of LOSB are available based on the unit discharge arrangement. LOSB is not available with optional Fresh Outside Air Duct intake.

TOP VIEW

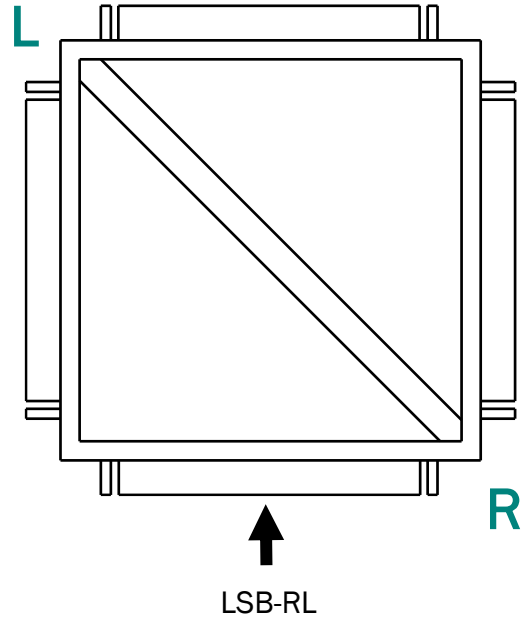
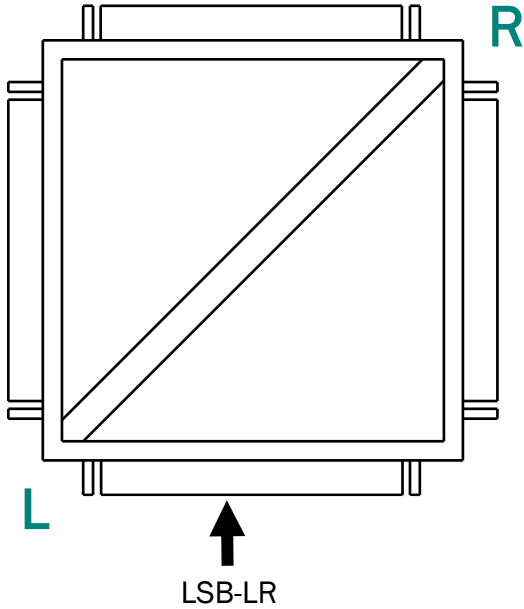

Line of Sight Baffle Configurations

VSHP - OPTIONAL FRESH OUTSIDE AIR INTAKE

Optional built-in Fresh Air Duct is suited for applications where the Energy Recovery Ventilator (ERV) unit is remote mounted. The factory installed fresh air intake accepts fresh air connection from a remote mounted ERV. Factory recommends Whisper Mode constant FAN-ON air circulation option with Fresh Air Duct option.

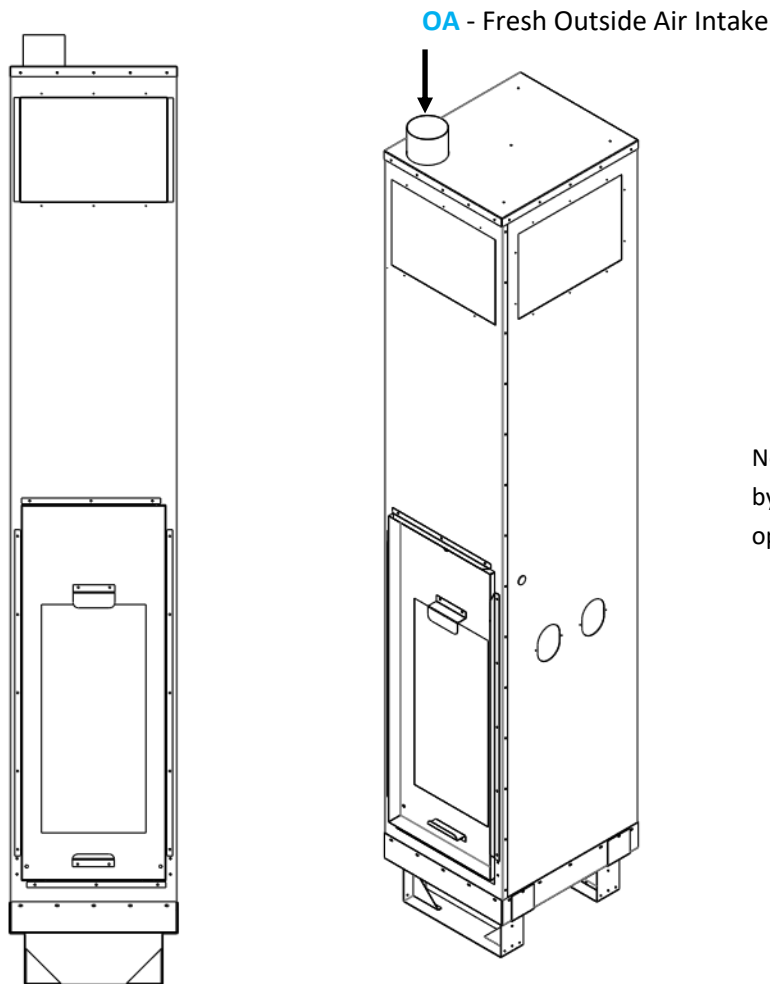

Note: Handing is referenced by facing the unit return air opening (front).



The introduction of cold conditioned outside air from a remote energy recovery ventilation device into the heat pump cabinet can result in potential freezing and bursting of mechanical components. All necessary precautions should be taken to temper Outside Air sufficiently above freezing point before entering the unit.

VSHP - OPTIONAL FRESH OUTSIDE AIR INTAKE—TOP DISCHARGE OPENINGS

Top discharge for VSHP cabinet with fresh air duct is available in two orientations: Horizontal and Vertical. Within each orientation, Omega offers (4) different configuration option for fresh air duct location. Line of sight baffle is not available with Fresh Outside Air Intake option.

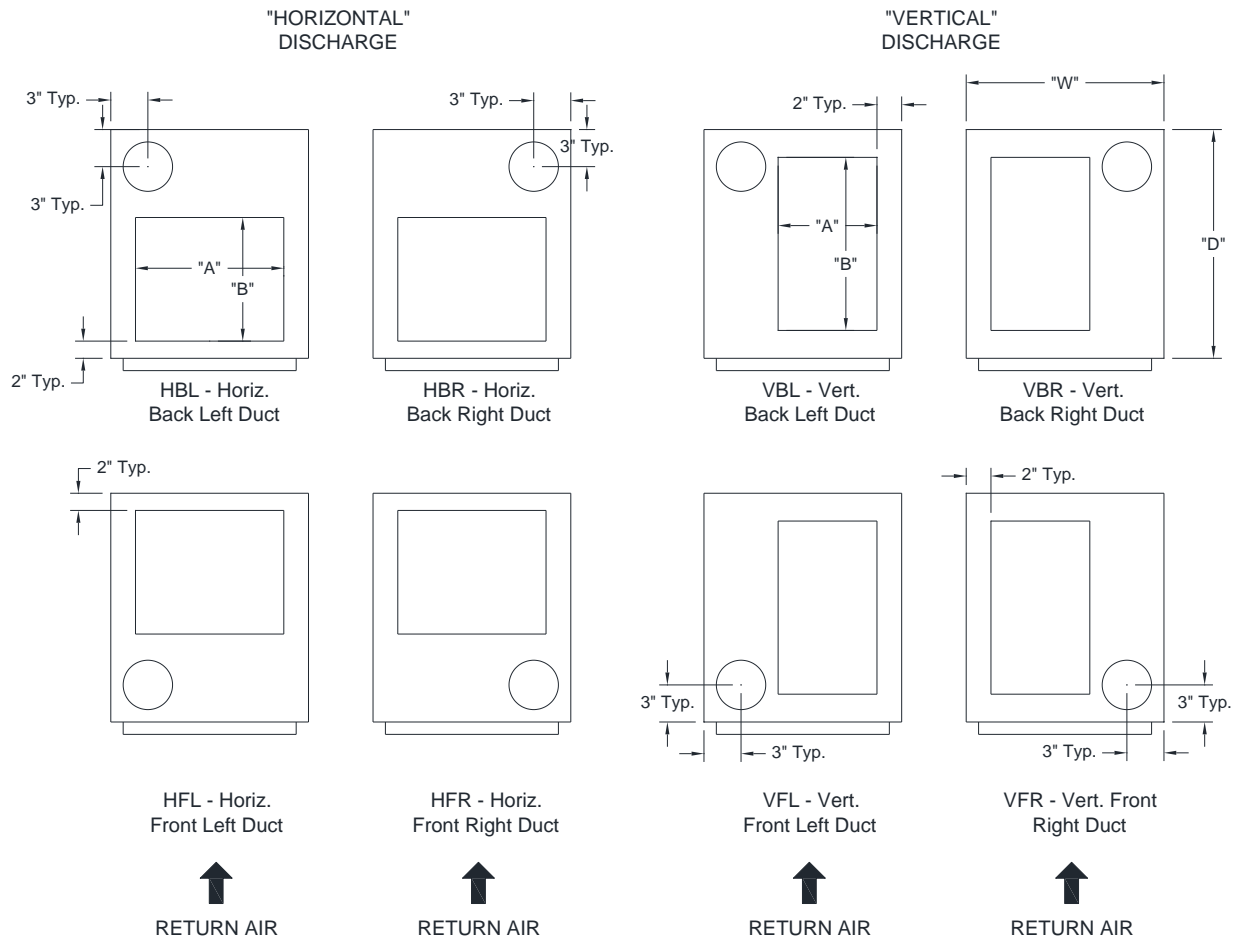

| Model | Cabinet Size | Dimensions (in) | | Top Supply Opening w/ Fresh Air Duct (A x B) inches | |
|-----------|--------------|-----------------|------|---|------------|
| | | "W" | "D" | "Horizontal" | "Vertical" |
| VSHP 020G | X | 16 | 17.5 | 12 x 8 | 8 x 12 |
| VSHP 030G | | | | 12 x 8 | 8 x 12 |
| VSHP 040G | | | | 12 x 8 | 8 x 12 |
| VSHP 050G | Y | 18 | 20.5 | 14 x 12 | 10 x 16 |
| VSHP 060G | | | | 14 x 12 | 10 x 16 |
| VSHP 080G | Z | 22 | 24.5 | 14 x 14 | 14 x 14 |
| VSHP 100G | | | | 16 x 14 | 14 x 18 |
| VSHP 120G | | | | 16 x 16 | 14 x 18 |

VSHP - RISER HANDING CONVENTIONS

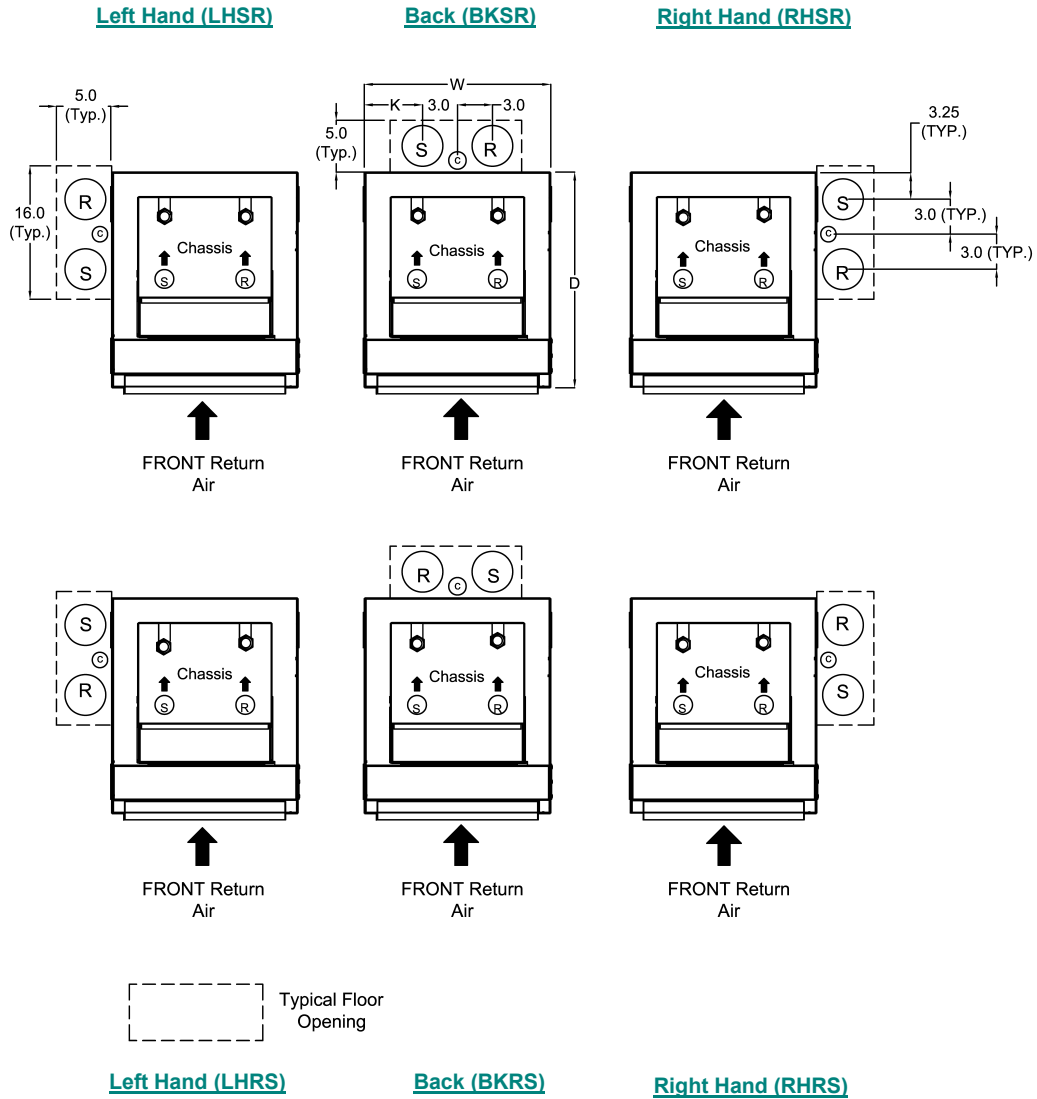

S = Supply Riser
C = Condensate Riser
R = Return Riser

| Unit Size | Cabinet Size | W | D | "K" (in) |
|---------------|--------------|----|------|----------|
| 020, 030, 040 | X | 16 | 17.5 | 5 |
| 050, 060 | Y | 18 | 20.5 | 6 |
| 080, 100, 120 | Z | 22 | 24.5 | 8 |

Note:

- Units do not come with a riser chase or riser sleeve. Depiction shown indicates typical coring openings.
- Supply & Return risers shown are 3-inch. Condensate riser shown is 1.25-inch.

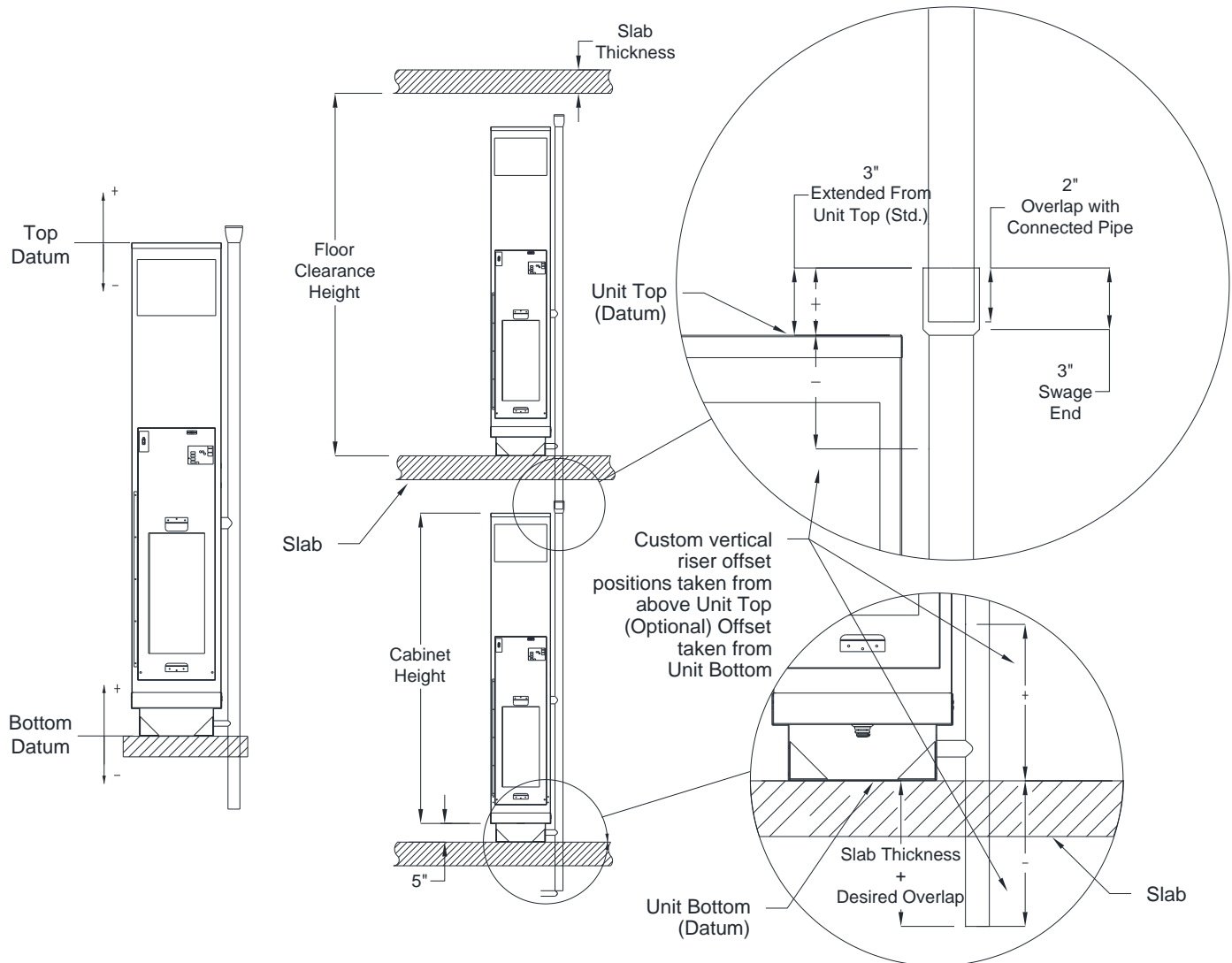
VSHP - RISER INSTALL DETAIL

Notes:

- Risers are positioned relative to cabinet using a standard "Top" Datum reference (optional "Base" Datum). Top Datum Offset indicates where the top of riser will be located relative to top of cabinet. A Base Datum indicates where bottom of riser will be located relative to base of cabinet.
- Upon request Omega will provide 3 inch deep swage on risers of same pipe size (optional for all risers) for connection to units on the floor below.
- Risers should insert 2 inches into the 3 inch deep swage connection (minimum 1 inch insertion is required)
- Riser Length = Floor Clearance Height + Slab Thickness + 2 inch (overlap).
- Omega supplies two standard riser lengths, 120" (10') and 144" (12').
- Extension tailpieces or transition reducers for joining piping are extra and field installed.
- Risers available in Type L and Type M copper.
- Condensate riser have optional 3/8-inch thick closed cell insulation to prevent condensation.
- Optional insulation on supply and return risers is also available in 1/2-inch, 3/4-inch and 1-inch thick as special. Insulation may limit maximum riser pipe size.

VSHP - HOSE KIT DETAILS

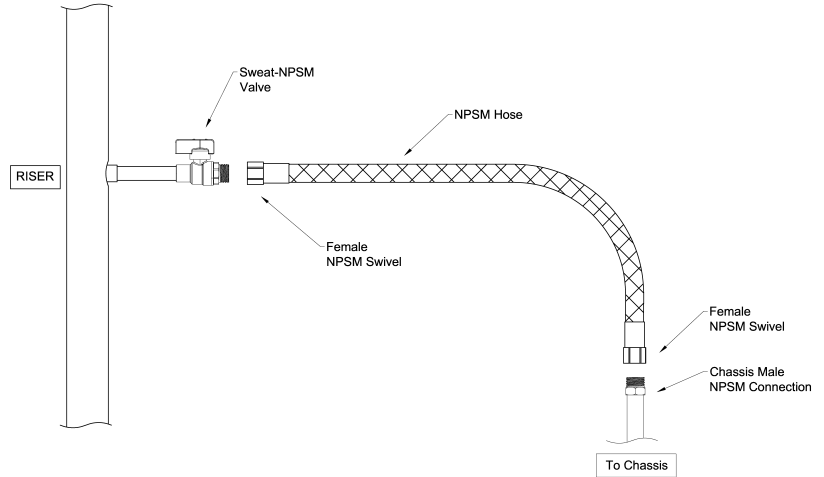
STANDARD VALVE - SWEAT CONNECTED NPSM



OPTIONAL FPT VALVE - FPT to FPT

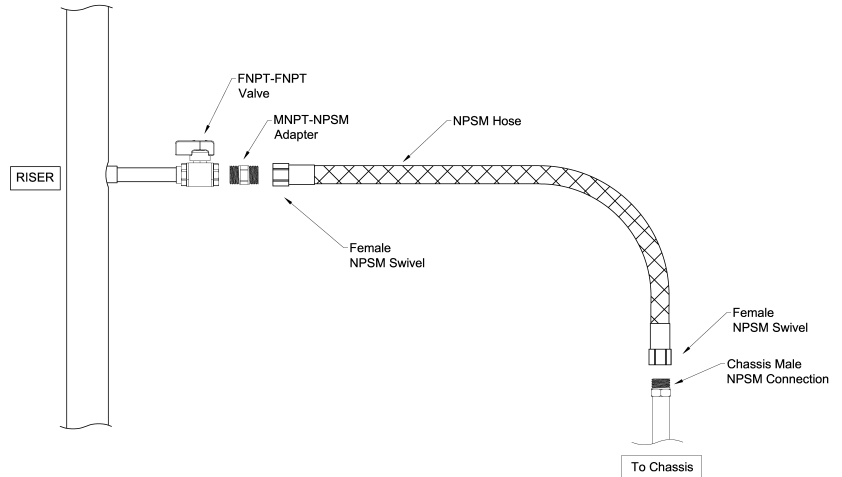

Hose Kit Sizes

| Model | Hose Kit | |
|-----------------|-----------|-------------|
| | Size (in) | Length (in) |
| VSHP 020 | 1/2 | 24 |
| VSHP 030 | 1/2 | 24 |
| VSHP 040 | 1/2 | 24 |
| VSHP 050 | 1/2 | 24 |
| VSHP 060 | 1/2 | 24 |
| VSHP 080 | 3/4 | 30 |
| VSHP 100 | 3/4 | 30 |
| VSHP 120 | 3/4 | 30 |

Isolation Valve Notes:

- Standard NPSM sweat connected isolation valves are for Factory or Field Supplied Copper Risers.
- Optional Female NPT valves are for Field Supplied Risers only. Includes MNPT-MNPSM hose adaptors with hose kit.

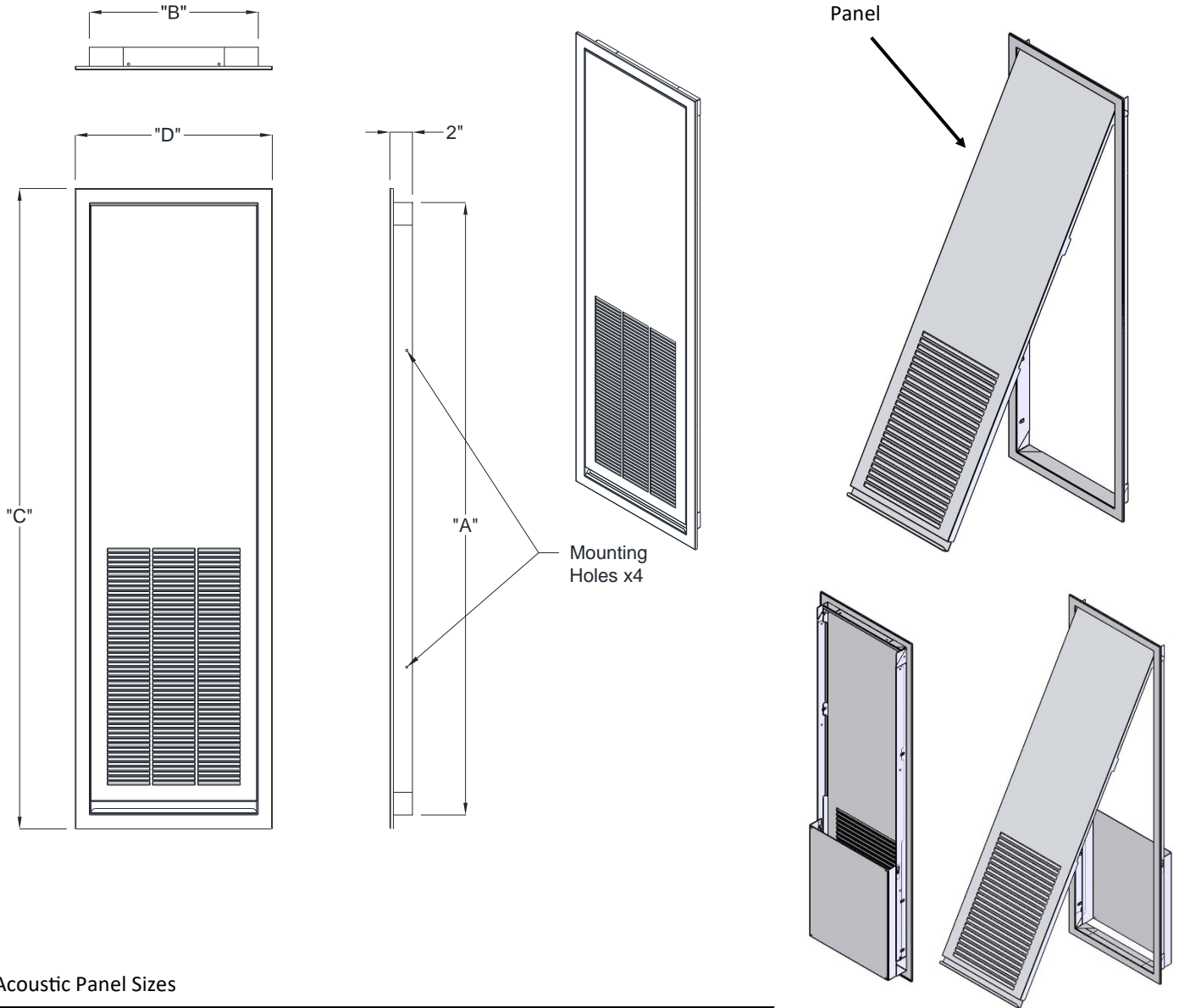
VSHP - ACOUSTIC RETURN AIR PANEL

Acoustic Panel Sizes

| Model | Cabinet Size | Acoustic RA Panel Dimensions (inches) | | | |
|----------|--------------|---------------------------------------|--------|--------|--------|
| | | A | B | C | D |
| VSHP 020 | X | 54 | 15 1/4 | 56 1/2 | 17 5/8 |
| VSHP 030 | | | | | |
| VSHP 040 | | | | | |
| VSHP 050 | Y | 54 | 17 1/4 | 56 1/2 | 19 5/8 |
| VSHP 060 | | | | | |
| VSHP 080 | Z | 54 | 21 1/4 | 56 1/2 | 23 5/8 |
| VSHP 100 | | | | | |
| VSHP 120 | | | | | |

 Optional Baffle¹
Notes:

- 1) Optional baffle requires additional 2-inch clearance.
- 2) Backside of RA Panel is insulated with 1/2 inch insulation.
- 3) Return air panel supplied in standard powder coat 'appliance white' finish.

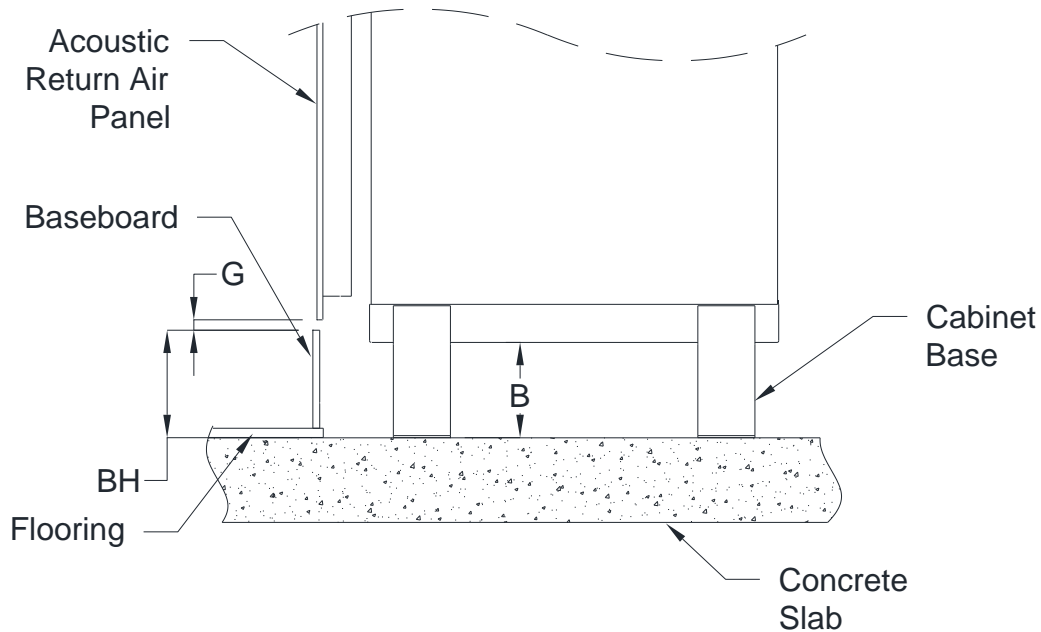
VSHP - ACOUSTIC BASEBOARD HEIGHT CALCULATION

Acoustic Panel Cabinet Base Height Calculation

Acoustic Panel Cabinet Base Height Calculation:

BH = Baseboard Height + Finish Floor Height*

G = Gap (min 0.5") between baseboard and panel.

B = Cabinet Base Height

(Min. 5", increases in 1" increments)

B = BH + G - 1.5"

Note: *Include flooring thickness, underlayment, and any concrete leveling as part of calculation.

Example:

If using a 5" baseboard, with 1" Finished Flooring height, and 0.5" gap:

$$B = (5" + 1") + (0.5") - 1.5"$$

$$B = 5"$$

Therefore a 5" Cabinet Base is required.

Example: Baseboard to Base Height Table

| Baseboard Height* | Cabinet Base Height |
|-------------------|---------------------|
| Up to 5" | 5" |
| >5" to 6" | 6" |
| >6" to 7" | 7" |
| >7" to 8" | 8" |

*Includes 1" Total Flooring

*Using gap G= 0.5" (from top of baseboard to return panel flange)

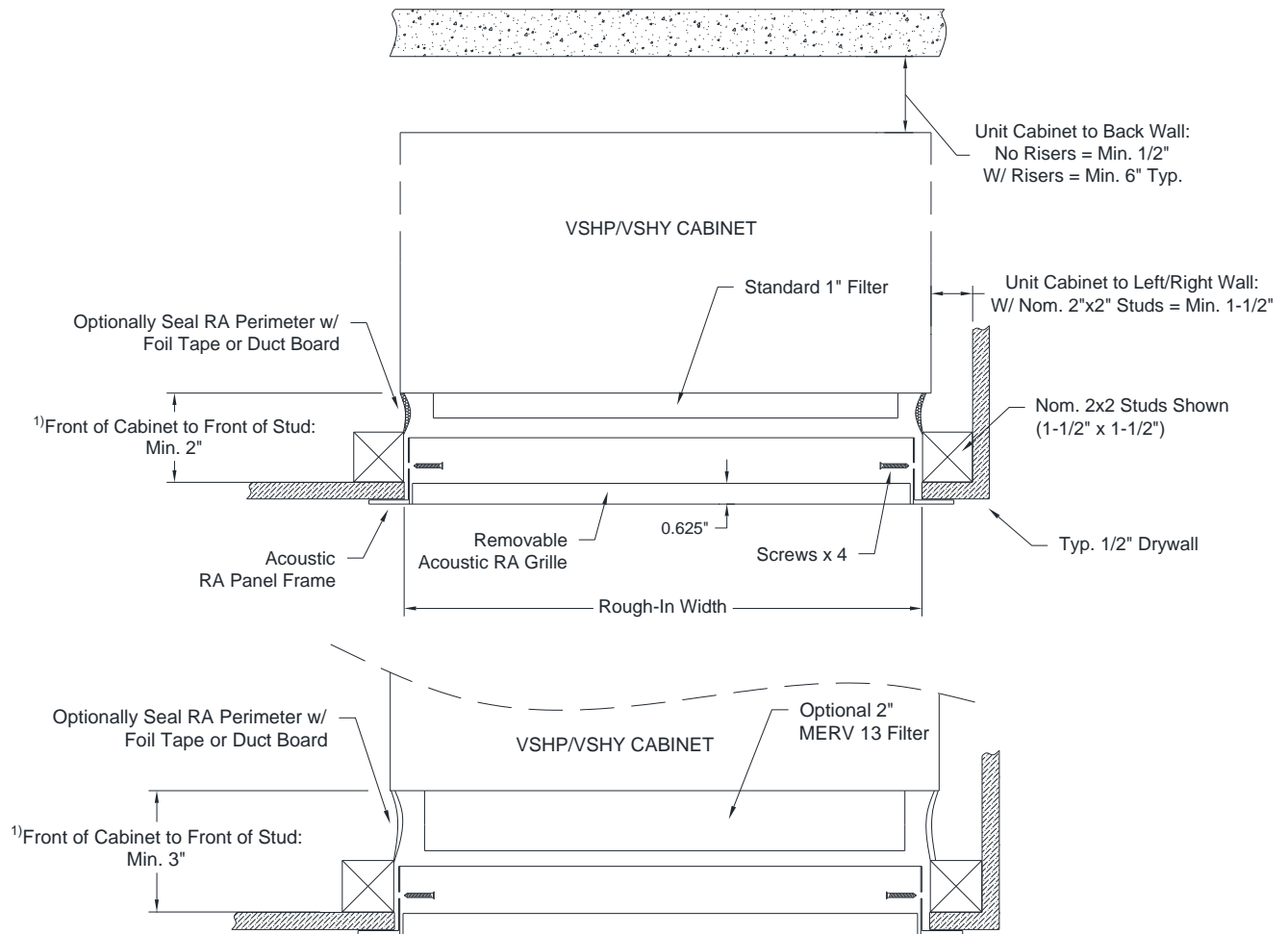
VSHP - ACOUSTIC R/A PANEL FURRING DETAILS

Acoustic Panel Furring Detail—Typ. 2x2 Framing Plan View

Notes:

- 1) Provide 2" from framing stud to cabinet. With optional 2-inch MERV 13 filter provide 3" from front of stud or min 1-1/2" from back of stud to cabinet. With optional flange, provide gap min. 1/2" from stud to flange.
- 2) Return air panel should be centered in front of the unit return air opening.
- 3) With rear/side risers, allow for min. 6" typical clearance at the rear/side of the units.
- 4) For additional sound attenuation insulate the closet cavity with plenum rated acoustical insulation.
- 5) With optional Baffle, allow for an additional 2-inch of clearance between stud and front of cabinet from what is indicated above.

VSHP - ACOUSTIC R/A PANEL ROUGH IN DETAILS

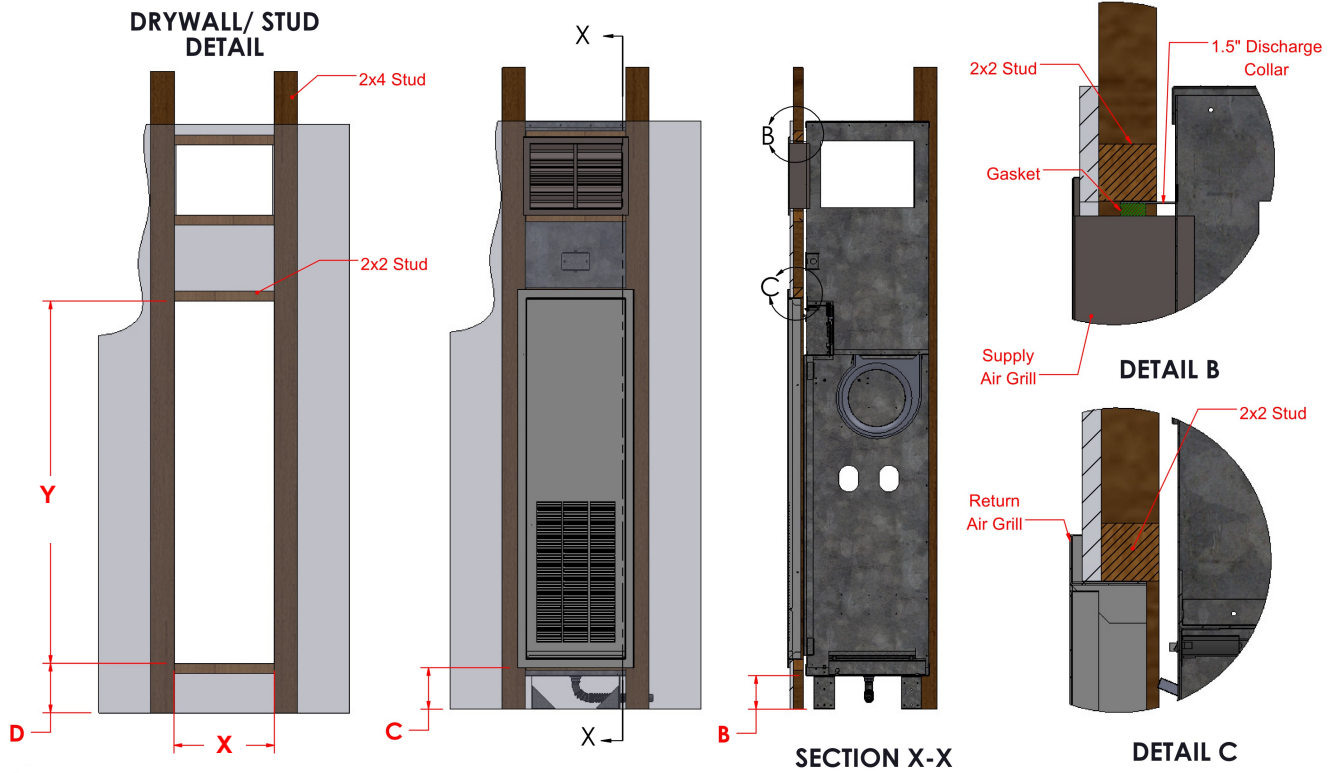

- B** = Cabinet Base Height (Min 5", increases in 1" increments)
- C** = Flange Height Above Floor (**B** + 1.25")
- D** = Rough-In Height Above Floor (**B** + 2.5")

Acoustic Panel Rough-In Dimensions

| Model | Cabinet Size | Cabinet Dimensions (in) | | Rough-In (in) | |
|-----------|--------------|-------------------------|--------|---------------|--------|
| | | W | D | "X" | "Y" |
| VSHP 020G | X | 16 | 17 1/2 | 15 3/4 | 54 1/2 |
| VSHP 030G | | | | | |
| VSHP 040G | | | | | |
| VSHP 050G | Y | 18 | 20 1/2 | 17 3/4 | 54 1/2 |
| VSHP 060G | | | | | |
| VSHP 080G | Z | 22 | 24 1/2 | 21 3/4 | 54 1/2 |
| VSHP 100G | | | | | |
| VSHP 120G | | | | | |

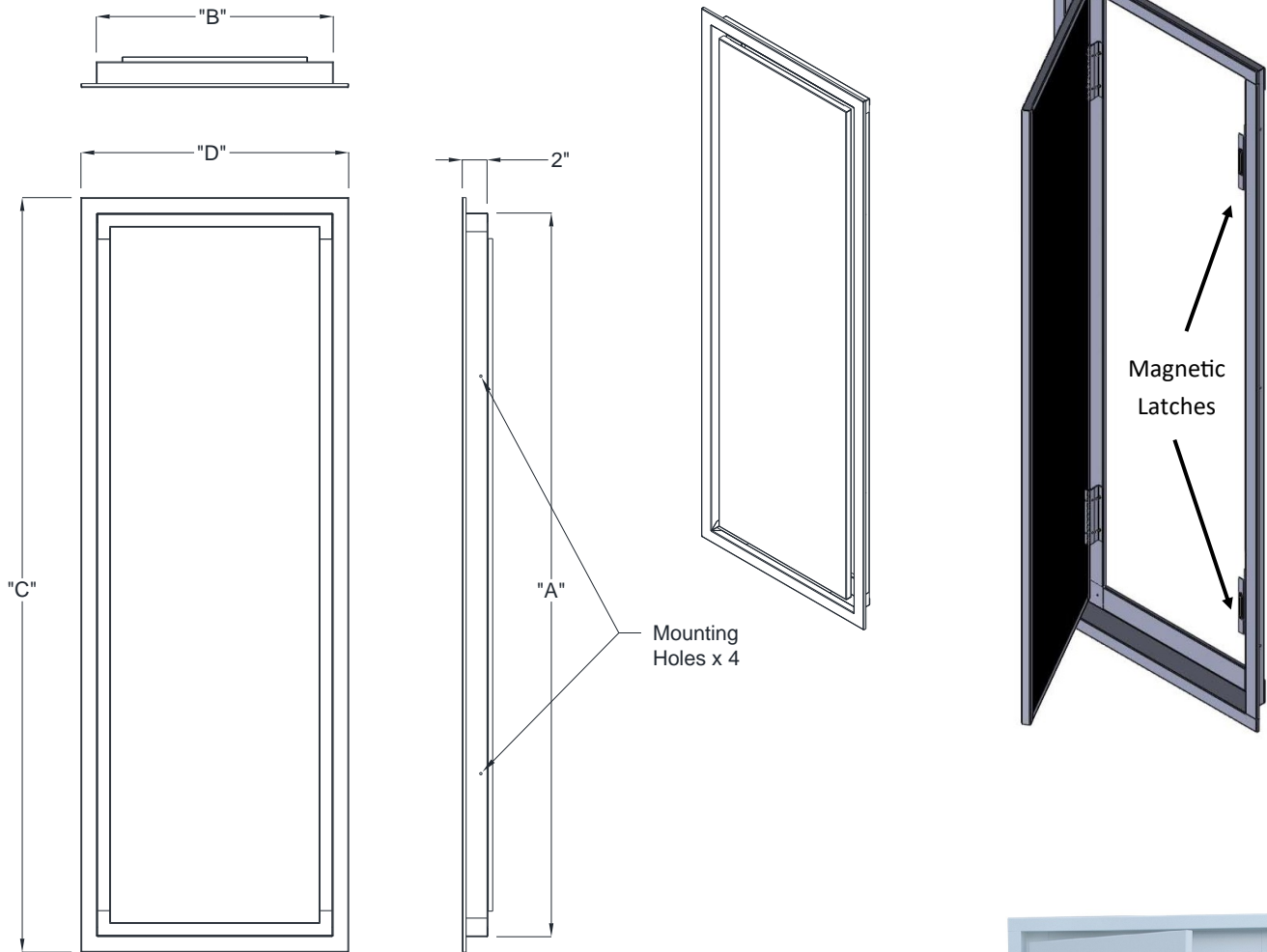
VSHP - PERIMETER RETURN AIR PANEL

Perimeter Panel Sizes

| Model | Cabinet Size | Perimeter RA Panel Dimensions (inches) | | | |
|----------|--------------|--|--------|--------|--------|
| | | A | B | C | D |
| VSHP 020 | X | 58 1/4 | 19 1/8 | 60 3/4 | 21 5/8 |
| VSHP 030 | | | | | |
| VSHP 040 | | | | | |
| VSHP 050 | Y | 58 1/4 | 21 1/8 | 60 3/4 | 23 5/8 |
| VSHP 060 | | | | | |
| VSHP 080 | Z | 58 1/4 | 25 1/8 | 60 3/4 | 27 5/8 |
| VSHP 100 | | | | | |
| VSHP 120 | | | | | |

Notes:

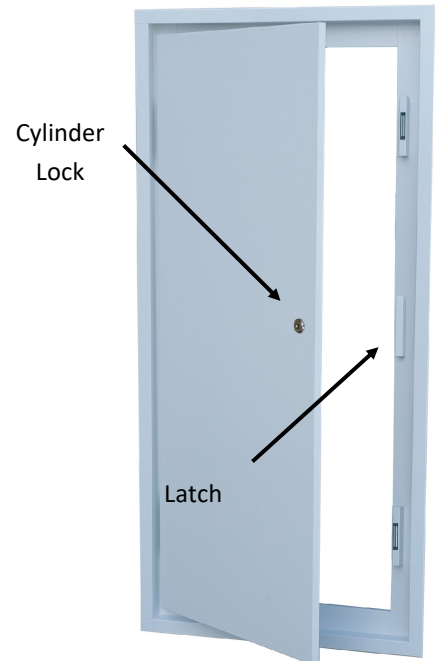
Backside of RA Panel is insulated with 1/2 inch insulation.
 Return air panel supplied in standard powder coat 'appliance white' finish.

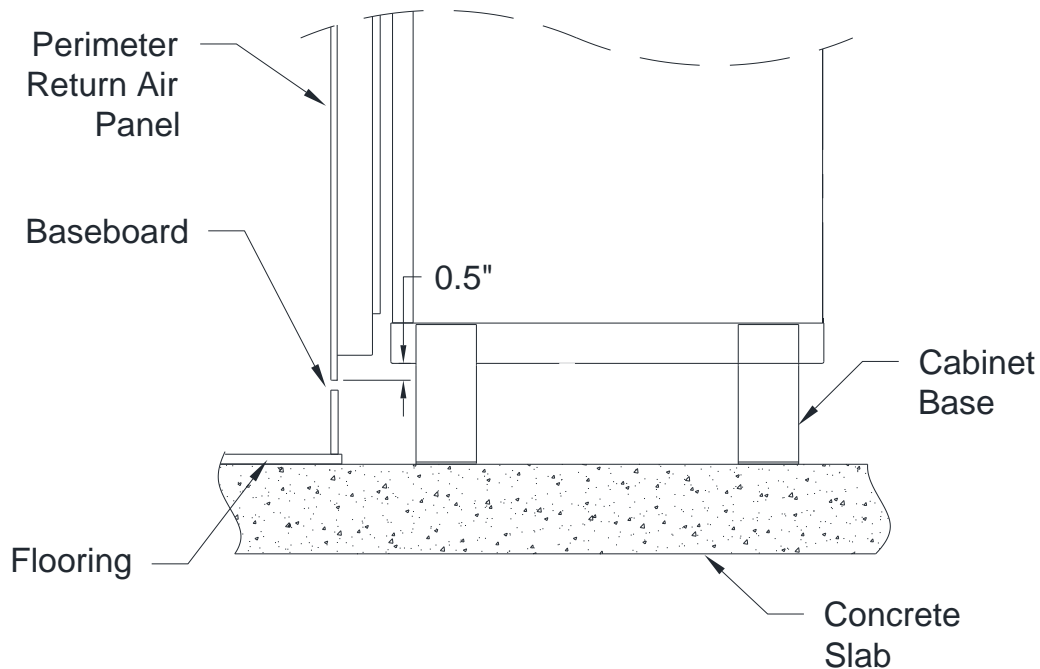

Optional Perimeter Locking Panel

VSHP - PERIMETER RETURN AIR PANEL - FURRING DETAILS

Perimeter Panel Cabinet Base Height Calculation

Perimeter Panel Cabinet Base Height Calculation:

BH = Baseboard Height + Finish Floor Height*

G = Gap (min 0.5")

B = Cabinet Base Height
 (Min. 5", increases in 1" increments)

$$B = BH + G + 0.5''$$

Note: *Include flooring thickness, underlayment, and any concrete leveling as part of calculation.

Example:

If using a 5" baseboard, with 1" Finished Flooring height, and 0.5" gap:

$$B = (5'' + 1'') + (0.5'') + 0.5''$$

$$B = 7''$$

Therefore a 7" Cabinet Base is required.

Example: Baseboard to Base Height Table

| Baseboard Height* | Cabinet Base Height |
|-------------------|---------------------|
| Up to 3" | 5" |
| >3" to 4" | 6" |
| >4" to 5" | 7" |
| >5" to 6" | 8" |

*Includes 1" Total Flooring

*Using gap G= 0.5" (from top of baseboard to return panel flange)

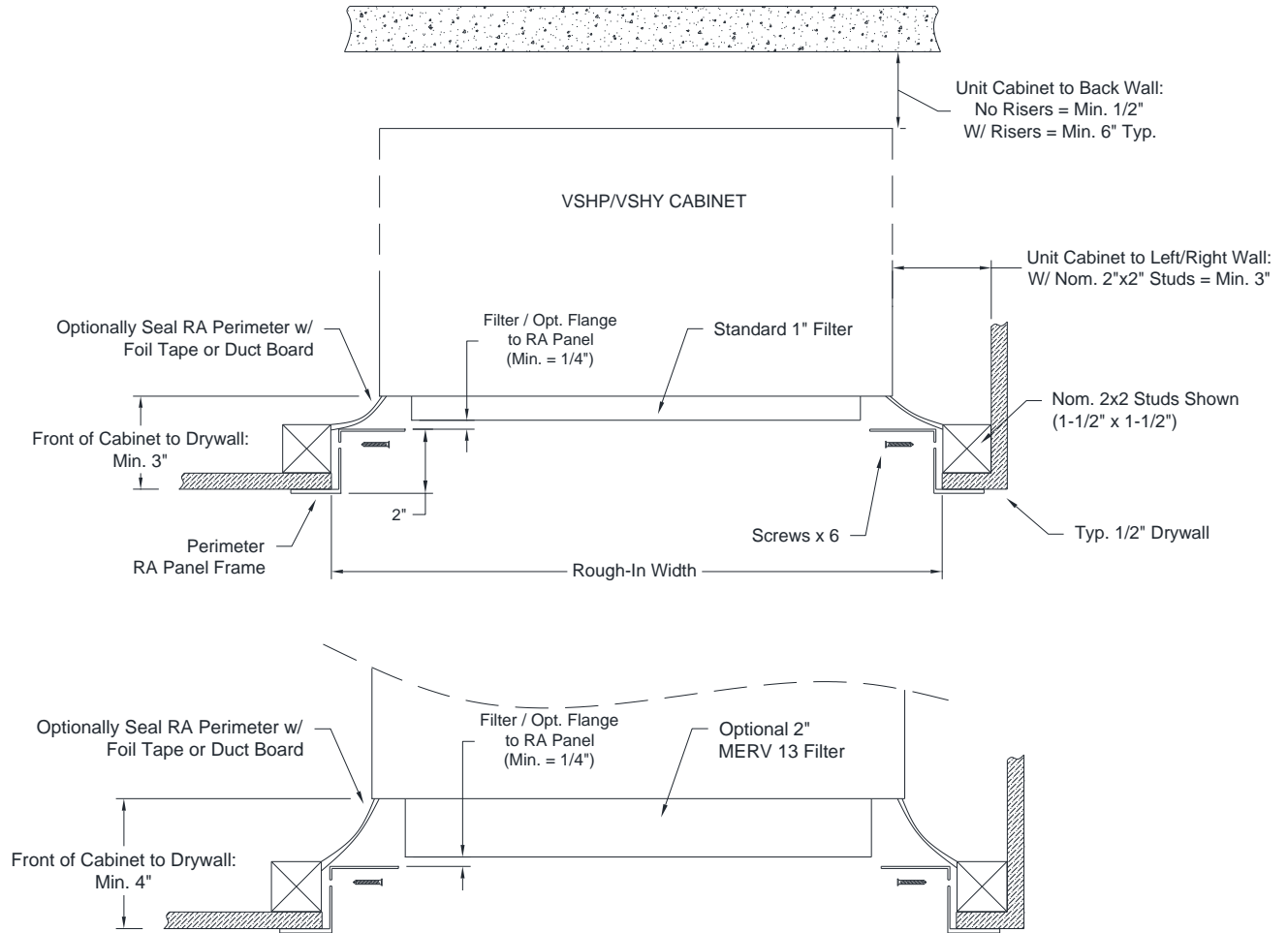
VSHP - PERIMETER RETURN AIR PANEL - FURRING DETAILS

Perimeter Panel Furring Drawing—Typ. 2x2 Framing Plan View

Notes:

- 1) Provide gap of 3" from framing finished drywall to cabinet. With optional 2-inch MERV 13 filter provide 4" from finished drywall to cabinet. With optional flange, provide gap min. 1/4" from RA Panel to flange.
- 2) Return air panel should be centered in front of the unit return air opening.
- 3) With rear/side risers, allow for min. 6" typical clearance at the rear/side of the units.
- 4) For additional sound attenuation insulate the closet cavity with plenum rated acoustical insulation.

VSHP - PERIMETER RETURN AIR PANEL FURRING DETAILS

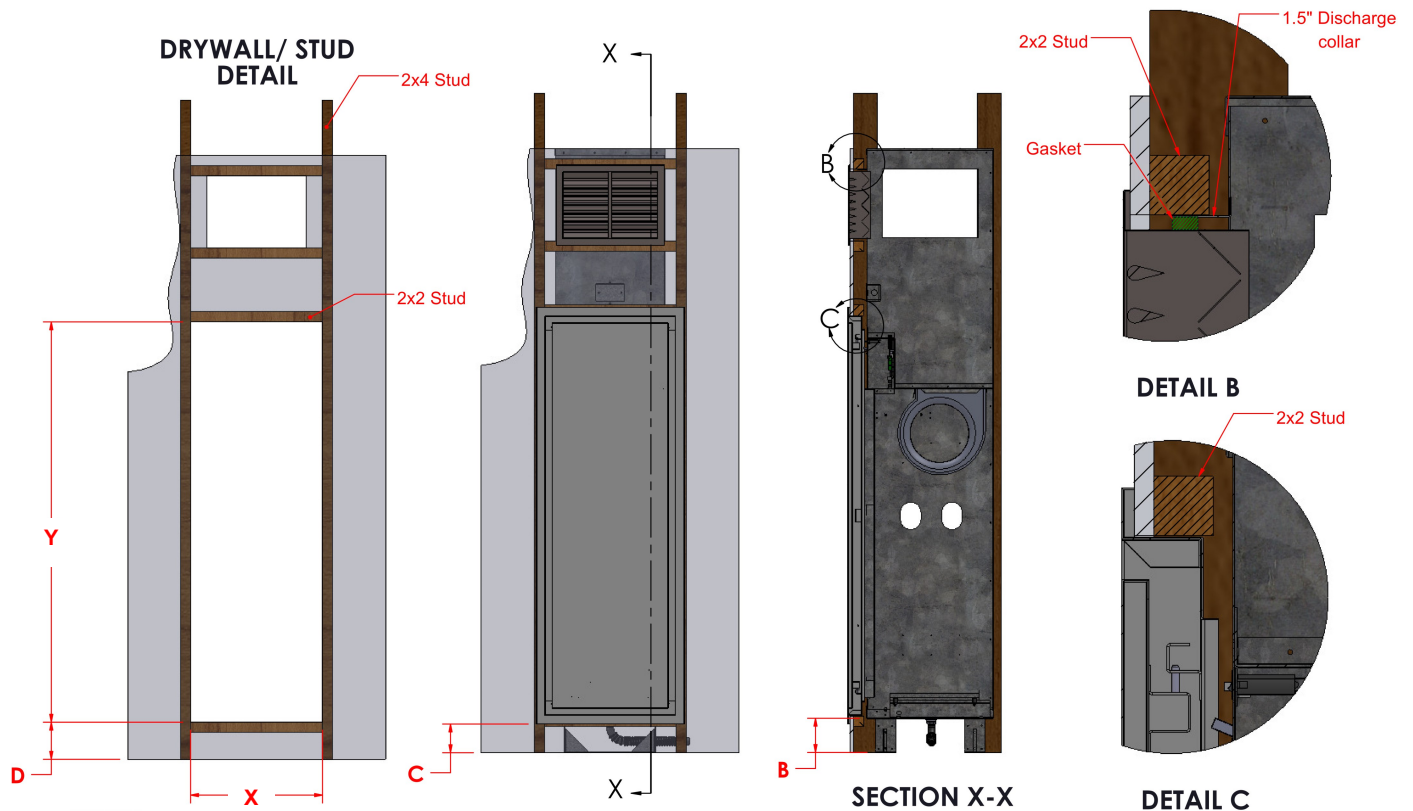

- B** = Cabinet Base Height (Min 5", increases in 1" increments)
- C** = Panel Flange Height from Base of Cabinet (**B** - 5")
- D** = Rough-In Height from Base of Cabinet (**B** + 0.625")

Perimeter Panel Rough-In Dimensions

| Model | Cabinet Size | Cabinet Dimensions (in) | | Rough-In (in) | |
|-----------|--------------|-------------------------|--------|---------------|--------|
| | | W | D | "X" | "Y" |
| VSHP 020G | X | 16 | 17 1/2 | 19 1/2 | 58 3/4 |
| VSHP 030G | | | | | |
| VSHP 040G | | | | | |
| VSHP 050G | Y | 18 | 20 1/2 | 21 1/2 | 58 3/4 |
| VSHP 060G | | | | | |
| VSHP 080G | Z | 22 | 24 1/2 | 25 1/2 | 58 3/4 |
| VSHP 100G | | | | | |
| VSHP 120G | | | | | |

VSHP - ELECTRICAL CONTROL WIRING

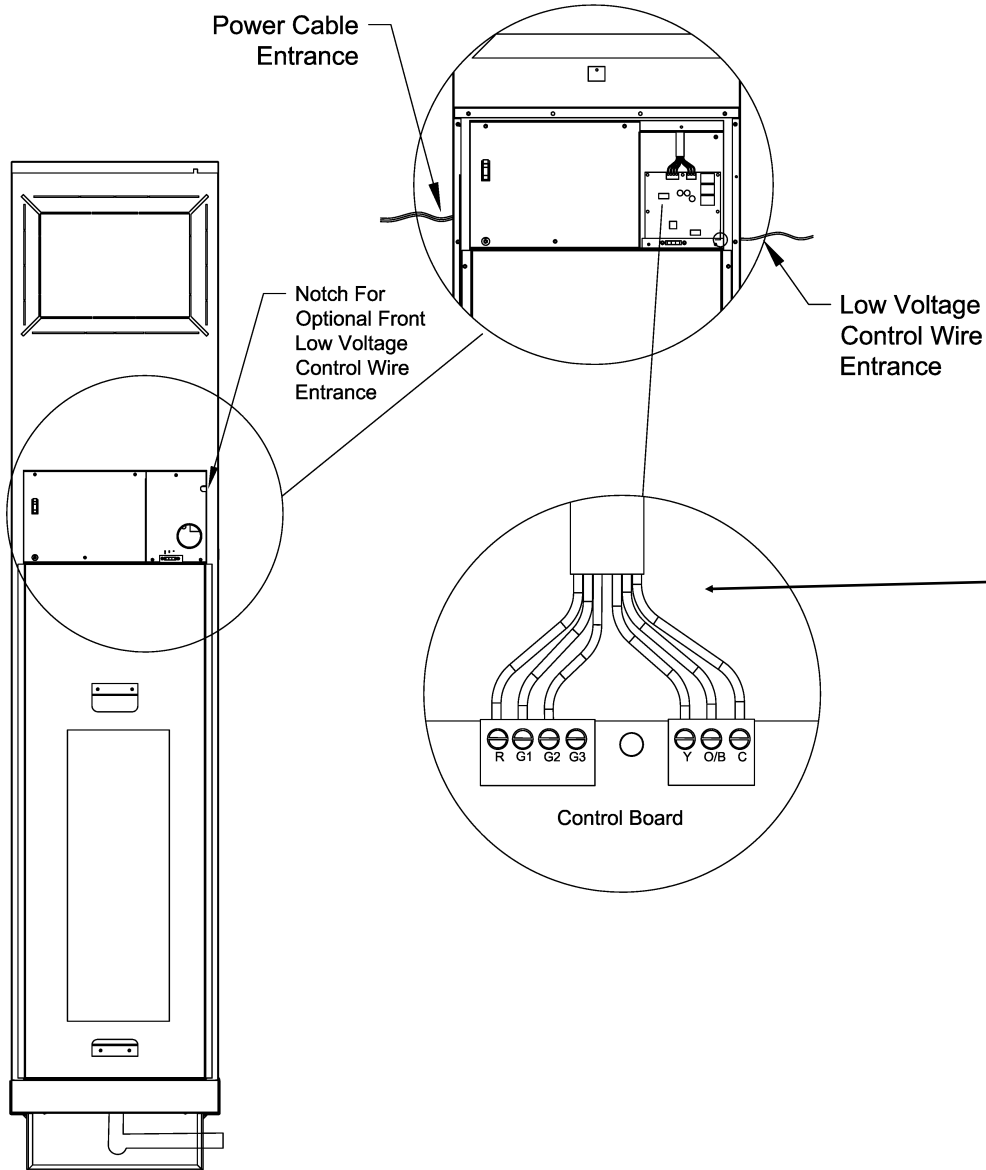

Field supplied 6-wire thermostat cable shown.

Min. 5-wire required for smart thermostats.

Heat Pump Thermostat:

- R = 24VAC
- G1 = Fan Speed 1
- G2 = Fan Speed 2
- G3 = Fan Speed 3
- Y = Compressor On
- O/B = Reversing Valve
- C = Common

Heat/Cool Thermostat:

- R = 24VAC
- G1 = Fan Speed 1
- G2 = Fan Speed 2
- G3 = Fan Speed 3
- Y = Cooling
- O/B = Heating
- C = Common

VSHP - CONTROLS

Fan Control with EC Motors (ECM)

Pulse Width Modulated (PWM) signal is utilized to control fan motor speeds between 0 and 100% of full speed. The controller has been programmed to use 3 pre-programmed speeds for Low, Medium and High. With optional Whisper Mode when there is a no request for cooling or heating, unit will operate in 'Whisper Mode' for ultra low fan speed air circulation.

Thermostat Connection

Units come with terminal block mounted to the control board to field wire thermostat cable pigtailed. A minimum 4-wire thermostat cable is required for basic single fan speed thermostats where common wire is not required. A 5-wire cable is recommended for most modern thermostats.

Ensure thermostat provides 24V power to G (fan) terminal during call for heating or cooling.

Fan Speed Set by Thermostat

Wire thermostat wire to required fan speed terminal and set DIP Switch #6 on the board to (ON) Auto. Fan speed will be determined by wiring to the G1, G2, or G3 terminals:

G1 Signal = LOW fan speed enabled.

G2 Signal = MEDIUM fan speed enabled.

G3 Signal = HIGH fan speed enabled.

Manual Fan Speed Control - 3-Speed Selector Switch

Enable the unit mounted 3-speed selector switch by setting DIP Switch #6 to OFF (Manual). Run fan wire from thermostat to any of the G1, G2, G3 terminals. Fan speed will be determined by the position of the unit mounted 3-speed fan selector switch:

L = LOW fan speed

M = MEDIUM fan speed

H = HIGH fan speed

SEQUENCE OF OPERATION

Call for Heating and Cooling

When a compressor request is made, the optional motorized auto shut-off control valve will open. The compressor contactor will then be energized so long as none of the following fault conditions are present:

- High-Pressure Alarm
- Low-Pressure Alarm
- **(Optional)** High-Pressure Water Alarm
- **(Optional)** Condensate Over Flow Alarm
- Compressor Anti-Short Cycle 7 min. timer has not expired
- **(Optional)** Entering Water Temperature (EWT) is greater

than 115°F

- **(Optional)** Leaving Water Temperature (LWT) greater than 127°F

When call for compressor request is terminated, the optional motorized auto shut-off control valve and the blower fan will remain open until the timers have expired.

Low-Pressure Bypass

During a call for compressor, the low-pressure switch is bypassed for the first 3 minutes of compressor operation to prevent nuisance low-pressure start-ups.

RST - Refrigerant Suction Alarm (Optional)

For standard or LTW option, RST sensor is set to 28°F. If running in Geothermal loop, the on-board Geo jumper may be cut to lower the RST alarm point to 7°F.

LAT - Leaving Air Temperature Alarm (Optional)

Leaving air temperature monitors supply air temperature and if temperature is detected below 35°F or above 131°F the LAT LED will flash solid during this time.

Timers and Interlocks

Microprocessor board utilizes a number of timers and interlocks in the control sequence of the unit.

Anti-Short Cycle Timer

The compressor anti-short cycle timer of 7 minutes starts every time a call for compressor is terminated to prevent compressor over cycling.

Fan-On/Off Timer

The Fan-On timer of 10 seconds starts anytime there is a call for fan request and 10 seconds after a call for compressor is terminated.

Valve Open/Closed Timer

The valve open timer of 1 minute starts anytime a fan and compressor request are made to develop flow in the water coil. The valve closed timer of 1 minute starts anytime a call for compressor is terminated to allow for flushing of the water coil.

Random Wait Time on Unit Power Up

Microprocessor controller uses a random wait time during unit start up between 1-30 seconds.

VSHP - Mechanical Specification

1 GENERAL

Install Omega series Vertical Stack Heat Pumps as indicated on the plans and capacities listed in the schedule and specifications.

Each unit shall be factory tested and ship factory-charged with R-410A refrigerant. All units from 1/2 to 3 Tons shall be tested and certified by ASHRAE/ANSI/AHRI/ ISO 13256-1 and ETL listed for United States and Canada. Each unit shall have factory affixed label showing ASHRAE/ANSI/AHRI/ISO and ETL logos. Cabinets and refrigeration chassis shall be factory wired and pre-piped.

2 CABINET

2.1 The vertical stacked heat pump units shall be **Omega VSHP Series**. Units shall provide scheduled capacities at the ampacity and voltage specified. Specified airflow shall be at the scheduled external static pressure and shall include the effects of a wet coil and clean filter.

2.2 The cabinet shall be 20-gauge galvanized steel with riveted internal components for rigidity. Cabinet shall have internal surfaces insulated with 1 inch thick, 3.5 lbs. high-density, mold resistant, thermal and acoustic insulation. Insulation shall meet NFPA 90, UL-181, and ASTM-C1071 standards and insulation shall have a flame spread of less than 25, and a smoke developed classification of less than 50 per ASTM E-84 and UL 723.

The unit shall be a single cabinet construction. Contractor shall be responsible for isolating the supply duct and supply grille from the cabinet.

(Optional GOLD Series) The cabinet shall be sectionalized using a factory installed canvas duct collar for acoustic and installation purposes. The lower section shall include the risers, blower and fan motor assembly, all controls, and removable refrigeration chassis. The upper section shall be an acoustic discharge plenum lined with 1 inch thick, 3.5 lbs. high-density, mold resistant, thermal and acoustic insulation. Final cabinet height shall be coordinated with the installing contractor and architect. The discharge plenum shall be designed to be fastened to the underside of the concrete slab with field cut "Knockout" discharge openings. Rigid connections will not be accepted. A factory supplied flexible canvas connection shall be provided between the upper and lower sections. Heat pump manufacturer shall factory attach flexible connection to the plenum section.

2.3 (Optional) Provide optional line of site baffles (LOSB) on all units with multiple unit outlets.

2.4 Physical dimensions of each unit shall be accommodated within furring / ceiling-slab spaces provided as shown on the architectural drawings

2.5 Provide a minimum 5" (optional 6", 7" and 8") high stand factory installed to the bottom of the sheet metal cabinet to elevate the unit 5" above the floor.

2.4 A removable inner chassis service panel allowing service access to the fan and compressor compartment shall be provided with each unit.

2.5 The drain pan shall be 16-gauge stainless steel. The drain pan shall come an optional condensate overflow switch. The drain pan outlet shall be readily accessible for cleaning with a 7/8 inch OD copper drain connection. Unit shall be provided with a flexible p-trap condensate hose for connection to the condensate riser.

2.6 Factory installed supply and return risers shall be (Type L)

(Type M) copper, with (factory) (field) mounted shut-off ball valves on each supply and return riser. Valves shall be brass and rated for 400 psig. A (Type L) (Type M) condensate riser shall be (factory) (field) installed. Risers sizes shall be installed according to building plans.

2.7 Risers shall have a (field) (factory) provided 3-inch deep swage. Transition pieces & expansion joints shall be field supplied.

2.8 Unit cabinet shall come with supply discharge opening "knockouts". An optional noise attenuating insulated privacy air baffle (LOSB) shall be provided, if available, for horizontal supply discharge openings. All cabinet discharge openings shall include 1-1/2 inch dry-wall flange around the full opening perimeter.

2.9 Supply ducts shall not be rigidly attached to the cabinet and shall be acoustically isolated from cabinet using flexible canvas connections. Contractor shall install flex connection on all discharge openings. There shall be no rigid connection to supply-air discharge grilles or supply ducts except on Gold Series units designed with split casing.

2.10 Each unit shall have an (Acoustic) (Perimeter) return air panel. The panels shall be insulated with 1/2 inch thick, lined fiberglass insulation. The panel shall be easily removable without tools to allow access to the filter, chassis compartment and (optional) service disconnect switch.

2.11 (Optional) A Baffle shall be provided with each Acoustic RA Panels for enhanced sound attenuation. Baffle contains 1/2" thick sound insulation. Installing contractor shall be provide additional clearances when framing closet opening.

2.12 (Optional) Unit shall have an optional Fresh Outside Air Duct intake located at the top of the unit for introducing fresh outside air into the unit.

2.13 (Optional) Each unit shall be (field) (factory) supplied with double deflection supply grilles as shown on the plans. (Field) (Factory) provide opposed blade balancing dampers on units with multiple outlets as indicated on the plans.

2.14 (Optional) Unit shall have an optional 2-inch filter rack with MERV 13 rated pleated filter.

2.15 (Optional) Perimeter Return Air Panels shall have provision for a unit mounted thermostat to meet ADA requirements. Thermostat cable shall use a moxex plug connector.

3 FAN & BLOWER

3.1 Each unit shall include a factory mounted forward curved, double inlet double width centrifugal direct drive fan and motor assembly with internal overload protection. The blower fan assembly shall be positioned horizontally from a sheet metal blower deck.

3.2 Units shall be supplied with an ECM, controlled using a PWM signal. Fan motors speeds shall be field selectable using unit mounted 3- speed fan switch or by compatible multi-speed thermostat. Units with fresh air option shall have an ultra-low 'Whisper' mode fan speed for air circulation when there is no call for compressor.

4 REFRIGERATION CHASSIS

4.1. Chassis shall be rated up to 400psig working pressure for the

VSHP - MECHANICAL SPECIFICATION (CONT'D)

water side circuit. Provide high temperature and pressure rated water hoses for connection of the risers to the chassis. The hoses supplied shall be constructed with an inner core of rubber, a stainless-steel metal braid, and rubber outer covering. Fittings shall be brass construction. Hoses shall carry a pressure rating of 600 psig.

4.2. The compressor chassis shall be mounted and vibrationally isolated on 12-gauge slide rails using a double isolated base. Compressor shall have an acoustical enclosure ensuring compressor noise is isolated from air stream. Provide plug type electrical connections for chassis control and power connections allowing for easy removal of the chassis from the front of the cabinet.

4.3 The refrigeration circuit shall have two service valves, for measuring high and low refrigerant pressure, in the chassis compartment enclosure. The refrigerant circuit shall contain a thermal expansion valve (TXV) refrigerant metering device and a reversing valve.

4.4 Compressor shall be hermetically sealed type with internal thermal overload protection. Compressor shall be mounted on rubber vibration isolators.

4.5 Air side coils shall have copper tubes mechanically bonded to aluminum fins. Coil shall be sized to meet scheduled performance for cooling and heating. Provide 1" T/A filter on coil face.

4.6 Water side condenser heat exchanger shall be coaxial type with steel outer tube and copper inner tube. Condenser shall be rated at 500 psig water side and 650 psig refrigerant side.

4.7 (Optional) The chassis shall employ an optional motorized auto shut-off valve to shut off water to the unit when compressor is not running. Valve shall be mounted in the chassis compartment.

4.8 (Optional) The chassis shall employ optional autoflow balancing valve mounted in the chassis compartment to maintain specified unit water flow rate over 2-80 psig differential water pressure. Auto flow balancing valve shall be field serviceable.

4.9 (Optional) Low Temp Water option: The chassis shall be factory supplied with a Low Temperature Water (LTW) kit. The LTW option shall be utilized for system water loops between 45°F and 55°F in heating mode that do not contain any glycol freeze protection. The chassis shall come with high water pressure safety switches factory installed.

4.10 (Optional) Geothermal option: The chassis shall be factory supplied with a geothermal kit. The geothermal option includes geothermal rated low-pressure switch, insulated coaxial and insulated water piping. Geothermal option must only be used on loop systems with glycol freeze protection added to the riser loop.

4.11 (Optional) Optional cupro-nickel coaxial coil shall be provided in lieu of standard copper coaxial for protection from loop water corrosion and fouling and with use in open loop systems.

5 CONTROLS

5.1 Each unit shall be factory wired with all necessary controls. Each unit shall come standard with a microprocessor controller mounted in the electrical box. Electrical box shall contain compressor and fan motor contactor, 24-volt control power transformer, terminal block for low voltage field wiring connection, and terminal block for main power electrical connection, unit mounted service disconnect switch.

5.2 The operating and safety controls shall be monitored by the microprocessor controller. Sensor parameters and timers shall be field

adjustable to meet site conditions. Controller shall have the following safety switches and sensors and timers:

- Low Pressure Safety Switch
- High Pressure Safety Switch
- **(Optional)** High Water Pressure Safety Switches
- **(Optional)** Condensate Overflow Switch
- **(Optional)** Entering Water Temperature sensor
- **(Optional)** Leaving Water Temperature sensor
- **(Optional)** Suction line freeze-stat temperature sensor
- **(Optional)** Supply Air Temperature sensor
- Compressor Anti-Short Cycle timer
- Water Valve Open and Closed timer
- Low-pressure bypass timer
- Random wait time on unit power up
- Fan-On and Fan-Off timer

5.3 Microprocessor controller shall have embedded webpage diagnostic capability for status updates, quick servicing and troubleshooting on site. Controller shall have data logging with stored alarm states, supply and leaving water temperature, suction line temperature, and supply air temperature readings. Access to controller status and data log shall be available through a smart phone device, tablet or laptop.

5.4 Microprocessor controller shall have 'future proof' feature to accept software updates. Microprocessor board shall be capable of being field updated with newer software patches or custom software as needed.

5.5 Thermostats shall be remote mounted. Unit will come with a 24V terminal block for field connecting a field provided thermostat pigtail to the controller board terminals. Thermostats can be either Heat/Cool or Heat Pump type. Thermostat shall provide 24V signal to G (fan) terminal during a call for cooling.

5.6 ECM fan speed % torque settings are field configurable using the imbedded Web based interface to meet site static requirements.

5.7 (Optional) Units shall come with a SmartOne compatible RS-485 communication add-on board and remote temperature sensor.

6 TESTING & WARRANTY

6.1 Each chassis unit shall be factory tested using a multi-step computer controlled testing equipment to prevent operator error during factory testing.

6.2 Warranty shall be for parts, 1 year not to exceed 18 months from date of shipment. (Optional) Provide 5 year compressor replacement parts warranty only.

7 EXECUTION

7.1 Units shall be installed neat and level on vibration isolation pads, supplied by heat pump manufacturer, and secured to floor.

7.2 Flush the system per manufacturer instructions before connecting chassis. Contractor shall join supply and return riser flexible hoses together in each cabinet for flushing purposes.

7.3 Installing contractor shall install risers and install riser transi-



VSHP - MECHANICAL SPECIFICATION (CONT'D)

tion piece connections where riser sizes change.

7.4 The hoses shall be installed in the field by the contractor. The flare fittings on the hoses shall be connected according to industry standard (Finger tighten then tighten with wrench while always using back-up wrench).

7.5 (Optional): Contractor shall make provisions for connecting fresh air duct to the optional fresh outside air duct intake located at the top of the unit cabinet.

7.6 (Add for Gold Units) Discharge plenum shall be fastened to the underside of the concrete slab for noise attenuation using appropriate industry accepted mounting practices.

7.7 Flush the system per manufacturer instructions before connecting chassis. The riser system shall be flushed, cleaned and commissioned before connecting chassis units to the riser system.

7.8 Contractor shall provide duct and grille canvas connections on all single piece (Silver Series) units.

7.9 Start-up of units shall be supervised by trained representatives of the equipment manufacturer.